

CMY55 flat-base

monostyle wrapping machines for flat-base chocolate pralines



	CMY55 CD speed up to 500 ppm	CMY55 CPA speed up to 450 ppm	CMY55 CB4 speed up to 500 ppm
models			
standard features	<p>MONOSTYLE belt-feeding wrapping machine for flat-base chocolate pralines. Each version is dedicated to a specific style (Double twist, Bunch/Envelope/Wallet, Open points) and is suitable for all the most common wrapping materials. The machine can be equipped with an automatic aligner to optimize product feeding.</p> <ul style="list-style-type: none"> Reliable product feeding and wrapping sequences Suitable for all kind of processed pralines: ENROBED, MOULDED, EXTRUDED, DEPOSITED, etc. Format CHANGE OVER TIME: less than 45 minutes HMI by color graphic Touch Screen No Product-No Paper device / Servo-driven paper feeding system Gentle and positive handling of product and wrapping material Product always under operator control both during feeding and wrapping sequences Good accessibility, easy cleaning, maintenance and size change-over operations 		
optionals	<ul style="list-style-type: none"> Automatic splicer for outer &/or inner wrapping material Spliced product reject device Cold seal for "Protected Double Twist" Predisposition for cooling system on feeding belts <p>Only for CMY55 CB4:</p> <ul style="list-style-type: none"> System for different cutting lengths between outer and inner wrapping material Properly oriented product outfeed on belt Date coder integration / Labelling on product bottom / Hot glue dispenser / Heat sealing device 		

technical data

	CMY55 CD/CPA/CB4
total weight	1700 Kg
total installed power	5 Kw
supply pressure average consumption	6 bar 800 NI/min
paint	RAL 7035 Gloss 80

product size range

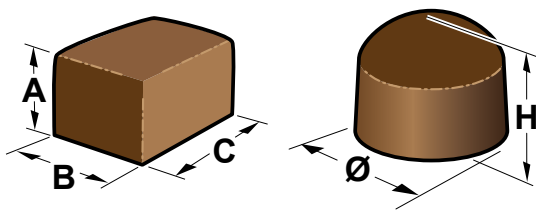

mm	A	B	C	H	Ø
min	5	18	25	12	22
max	25	35	60	28	35

Dimension next or beyond the limits of the above range to be evaluated.

layout

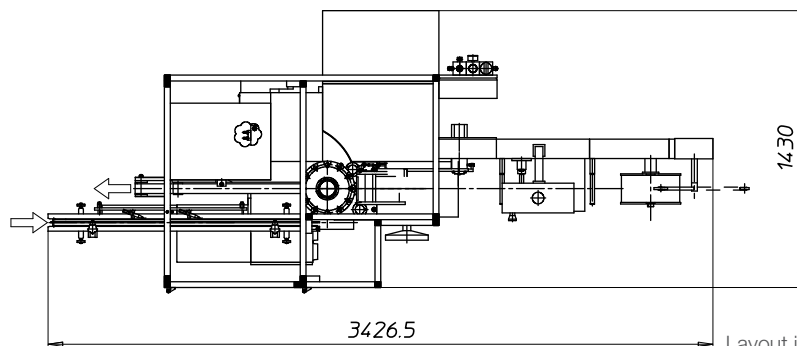
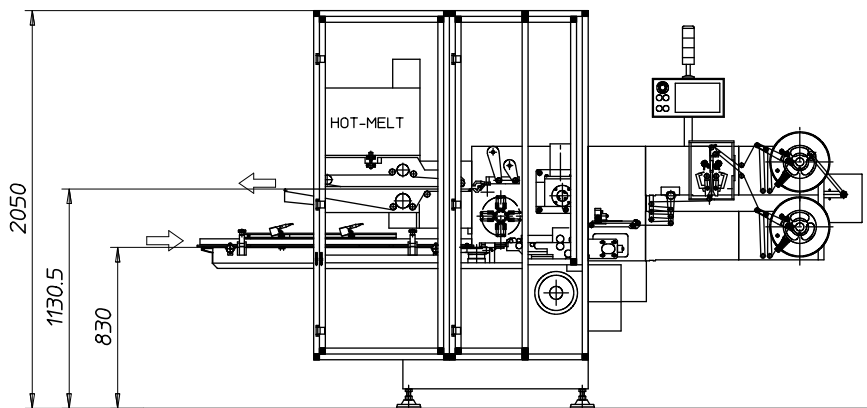

Layout is only indicative.



CMFima S.r.l.

Via Ca' Bianca, 730
 40024 | Castel San Pietro Terme (BO) | Italy
 Phone +39 051.07 09 011
 Fax +39 051.07 09 012
www.cm-fima.com

