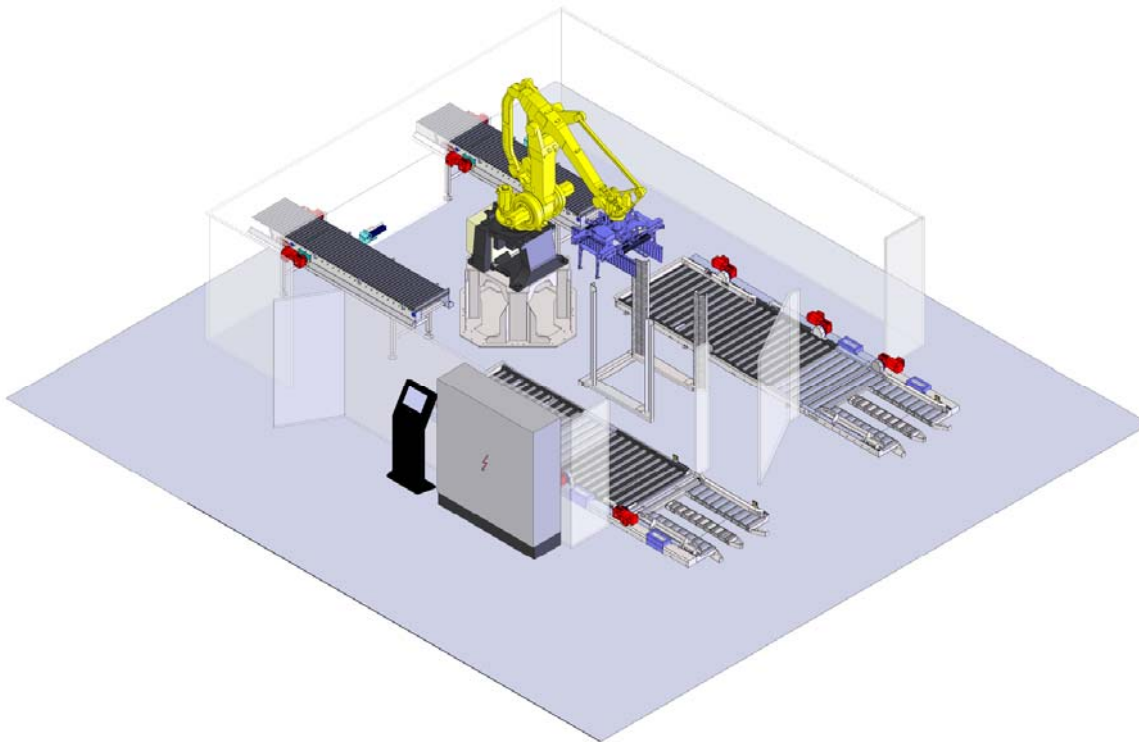

# HIGH PERFORMANCE PALLETIZER

by **OASI.S**

This high speed and flexible palletizer, proposed by CM-OPM in partnership with OASI.S

- Up to 3 different product line palletizing
- High efficiency
- Easy maintenance
- User Friendly
- Compact design
- Systems are easily re-configurable (protection of the investment)

**STANDARD FEATURES**

- Up to 3 different product line palletizing (4 lines with full layer picking)
- 4 axes robot palletizer
- Standard payload 185 kg, maximum payload available 700kg
- Palletization sequence available: by single pack, by partial layer, by full layer
- Product frames are prepared on the product conveyor
- Single multi-function pick-up head for the coordinated handling of: products, empty pallets and interlayer sheets Special grippers available for different packages
- Electronic receipt programming
- Possibility to connect the palletizer to a labeling and wrapping line
- Easy integration of AGV handling system
- Completely unmanned operation available
- MIMO palletizing workcells available (multi input and multi output)



Example of high performance palletizer installation.

Two twin palletizing robots with two products lines each.  
A shuttle conveys full pallets to the wrapping lines and hands over empty pallets to the palletizing cells.

Installation at a food company in Settimo Torinese (Italy).

Side pick-up universal tool



Barrel handling tool



Product handling pick-up on top and bottom



Vacuum gripper for boxes and pallets



Special tool for case stacker and destacker



Special vacuum gripper for glasses

