



PENTA XE

Overwrapper

- Complete overwrapping with envelope side fold seals
- Quick format change over
- Wide range of formats
- Short footprint
- Minimum maintenance requirements
- Speed up to 120 cycles/minute

EASY RIDE FOR DIFFICULT PRODUCTS

Penta XE is a high speed overwrapper with an excellent wrapping quality. Fully servo driven movements, high quality construction and the application of advanced technology, make Penta a fast and reliable machine.

PENTA XE

Overwrapper



TECHNICAL DATA

Max mechanical speed up to 120 cycles/minute

Max absorbed power 12 kW

Weight of basic machine 1050 Kg

SIZE RANGE

REEL	H	L
min.	230	356
max	750	1150

PRODUCT INFEEED

IN LINE	a	b	c
	min.	25	15
max	160	80	300

90°	a	b	c
	min.	60	25
max	350	80	160

BUNDLE

	A	B	C
min.	25	15	60
max	130	80	300

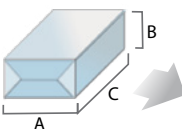
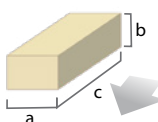
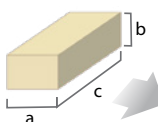
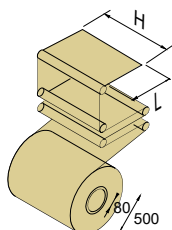

Measures in mm. Modifications can be made for formats exceeding the standard limit.

LAYOUT

IN LINE INFEEED

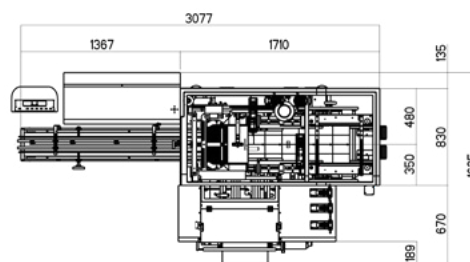

90° INFEEED

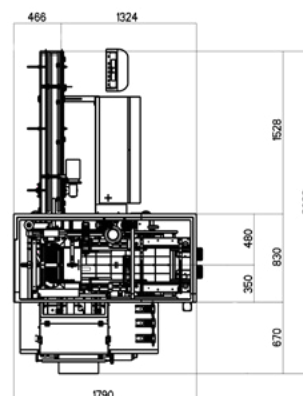

FLOW CHART

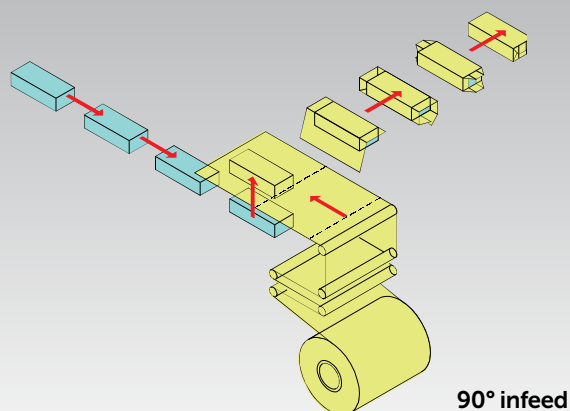
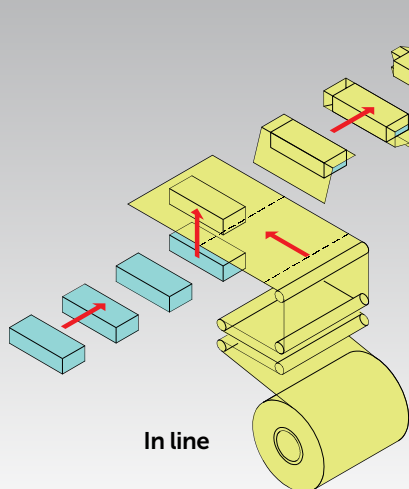

PIERREBI machines comply european standard for work safety (CE mark), and they are supplied with detailed technical informations. Technical data and illustrations are not binding; PIERREBI reserves the right to change the specifications of its machines at any time.

PIERREBI SRL

Via Dell'Artigianato,31 - 48014 Castel Bolognese (RA) - Italy
Tel. +39 0546 656131 - pierrebi@pierrebi.it

