

**SECONDARY
PACKAGING****PERFORMANCE S232**Forms, loads and closes
cartons and trays

a tri-functional cell configuration

A single machine formed by one, two or three modules, designed to form, load and lid/close boxes and displays or american cases without the space requirements of one/two/three separate machines.

Its completely modular structure allows a compact design and the ability to work even with difficult packaging patterns and layouts.

Suitable for a wide products in the food, cosmetic and pharmaceutical fields.

STANDARD FEATURES

- High modularity
- Integrated electric panel
- Reduced amount of space
- Easy accessibility from all sides
- Mono-bi-trifunctional configurations
- High performances
- Multiple possibilities of forming and closing options
- Robot equipments according to any customer's requests

LAYOUT

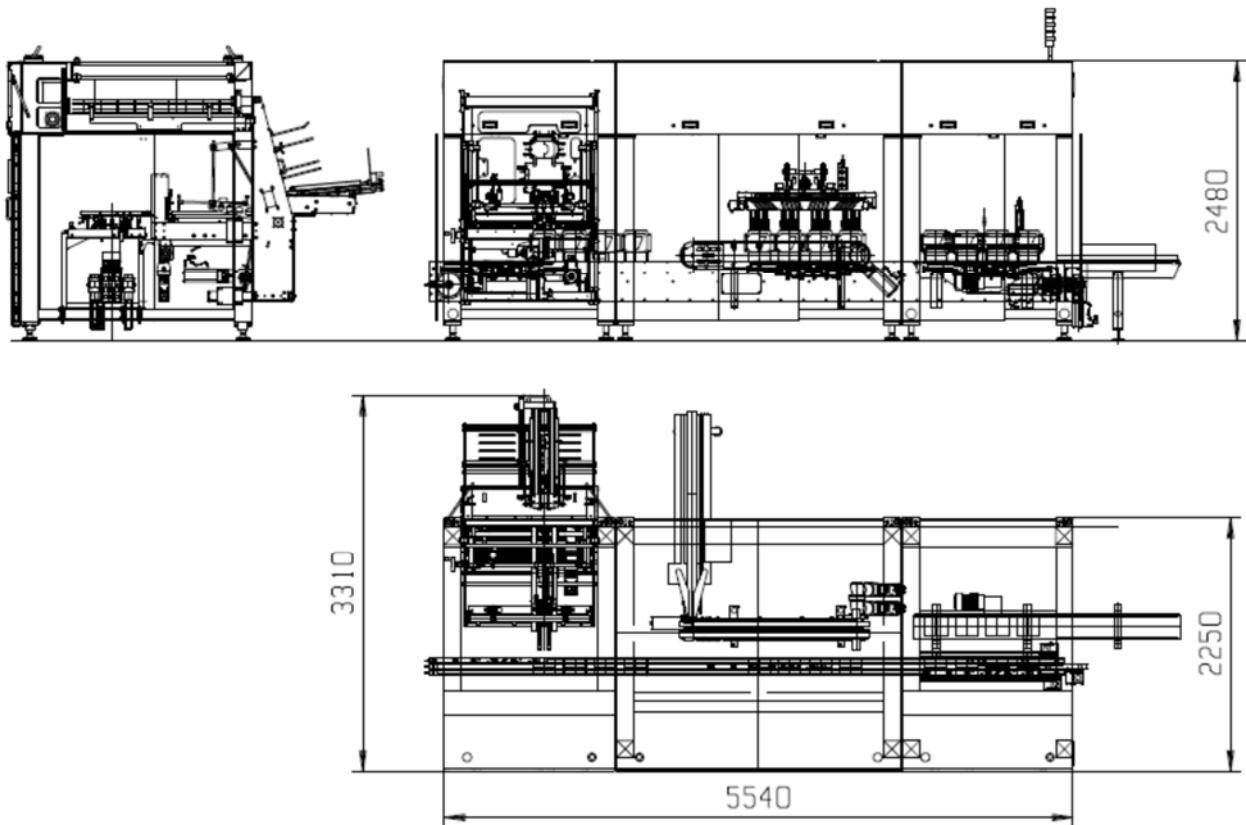

Example of a layout of a SACMI Packaging & Chocolate TLP.

This unit is suitable for high speed packaging of candy bars including the following functions:

- Carton forming from flat blanks (with single or double head forming)
- Infeed bar collation via vertical collating unit
- Carton filling by TLP top-loading robot
- Carton sealing
- Carton closing up to 30 products per minute
- Carton lidding up to 60 products per minute

The strongest element of this cell is the infinite possibility of modularity and customization that let us solve your most complex problems with a minimum requirement of floor space thanks to the utilization of state-of-the-art technology.

This kind of machine is suitable also for a wide product range, including candy bars, bags, jars, pouches, boxes and many other products in the food, cosmetic and pharmaceutical fields.

