

TRAYPOCKET

Horizontal tray packer

LITTLE THINGS ARE IMPORTANT TOO

Traypocket is an extremely compact and flexible monobloc machine for trays and small boxes. It can absorb high production capacities from several upstream lines.

- Product collecting unit at high speed
- Fully servo driven
- Quick size changeover
- Great flexibility in handling a wide range of products and packages (trays, boxes, displays with or without cover)
- Speed up to 40 cycles/minute
- Cantilever design for easy access and cleaning

TRAYPOCKET

Horizontal traypacker



TECHNICAL DATA

Max mechanical speed	up to 40 cycles/minute
Max compressed air consumption	5+6 NL/cycles
Working pressure	6 BAR
Max absorbed power:	10 kW

SIZE RANGE

Measures in mm.
Modifications can be made for sizes exceeding the standard limit.

TRAY

	A	B	C
min.	70	40	70
max	250	120	250

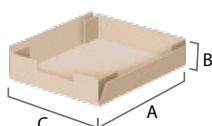

BOX

	A	B	C
min.	70	40	70
max	250	200	250

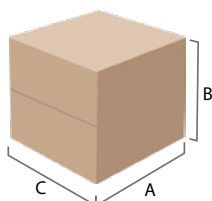

LAYOUT

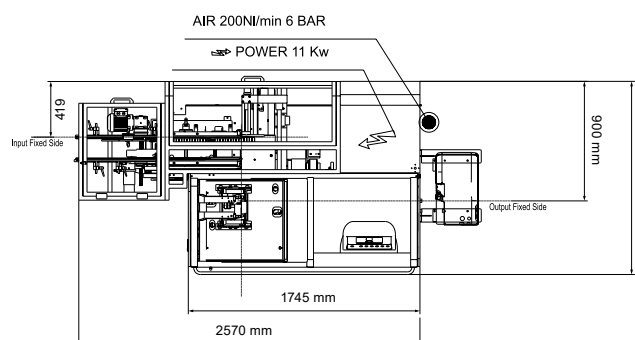
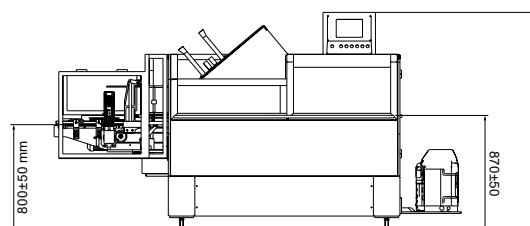

INFEED

AB

AU

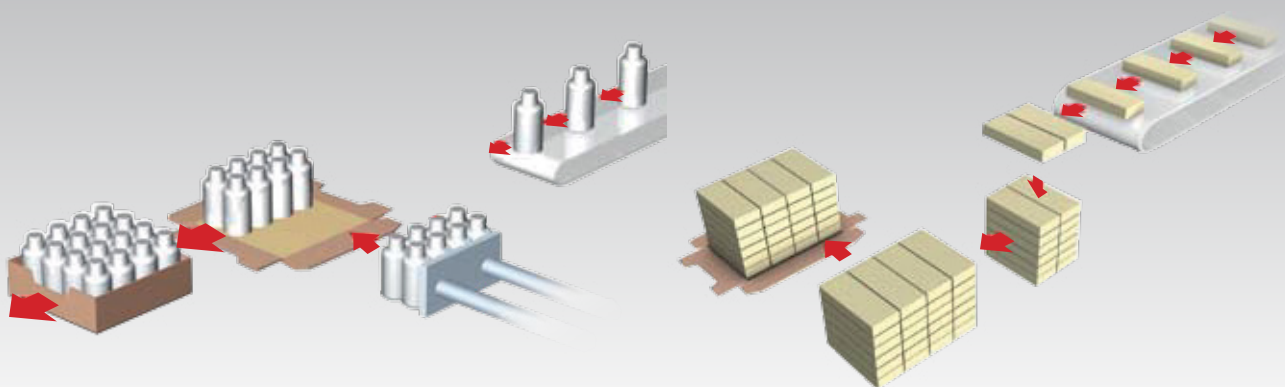

PIERREBI SRL

Via Dell'Artigianato,31 - 48014 Castel Bolognese (RA) - Italy
Tel. +39 0546 656131 - pierrebi@pierrebi.it

